

# 215s-10 Bicolor Clutch



## Suggested yarn:

- Pierrot Yarns Wild Life [100% hemp; 120 yds/110m per 3.53 oz./100g hank];
  - version A:
    - color #03 salvia blue, 3 hanks [245g]
    - color #05 spring green, 1 hank [95g]
  - version B:
    - color #02 beige, 3 hanks [245g]
    - color #14 blue black, 1 hank [95g]
  - version C:
    - color #01 white, 3 hanks [245g]
    - color #04 sky blue, 1 hank [45g]
    - color #17 purple, 1 hank [50g]
  - version D:
    - color #08 ocean blue, 2 hanks [120g]
    - color #09 pink, 2 hanks [125g]
    - color #13 olive drab, 1 hank [95g]

## Tools/Notions:

- 5.0mm (US H) and 6.0mm (US J) crochet hook or size necessary to achieve gauge

## Finished measurements:

- width 30cm/11.81"      • height 21cm/8.27"

## Gauge (10cm/4" square):

- pattern stitch w/6.0mm (US J) crochet hook: 12 sts and 14 rows

*Gauge may vary according to individual crochet style. Change hook size if necessary to achieve gauge. Alternatively, rework pattern with your own gauge measurements.*

## Summary

❖ **Note 1:** Like all Japanese patterns, stitch counts given here for foundation chains do **not** include any chain sts needed for turning posts.

❖ **Note 2:** Work body of clutch with 2 strands of yarn held together. (For versions C and D, some sections will be worked with 2 strands, each of a different color). Sc edging worked with 1 strand of yarn. Refer to schematic for color sequences.

**Body:** Work foundation chain to begin, then work in sc. Change color for flap and continue working in sc.

**Finishing:** Fold body of clutch where indicated. Seam sides by working sc edging around edges.

## Abbreviations:

ch = chain      sc = single crochet (US)

## Body of clutch

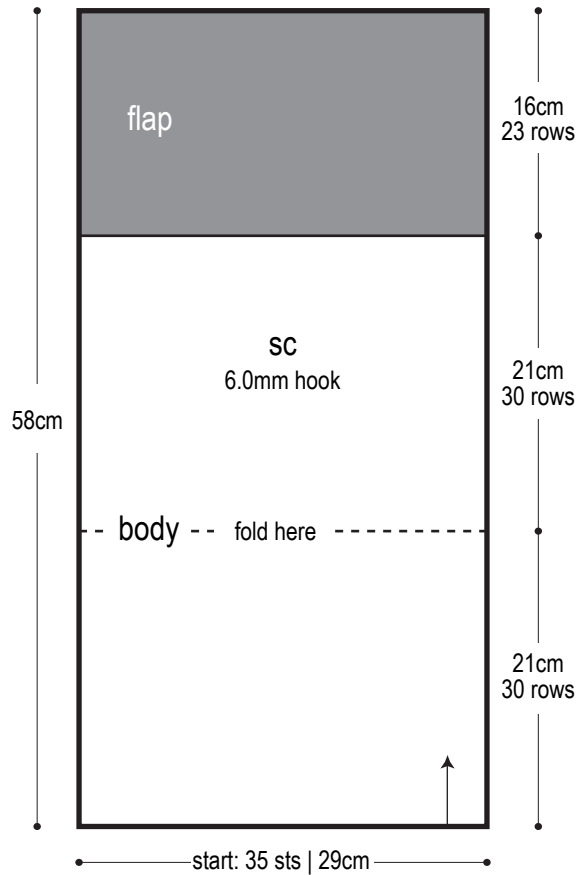

## Color sequences

	body	flap	body edging	flat edging
A	#03 salvia blue	#05 spring green	#03 salvia blue	#05 spring green
B	#02 beige	#14 blue black	#02 beige	#14 blue black
C	#01 white	#04 sky blue #17 purple	#01 white	#04 sky blue #17 purple
D	#08 ocean blue #09 pink	#13 olive drab	#09 pink	#13 olive drab

## Finishing

5.0mm hook

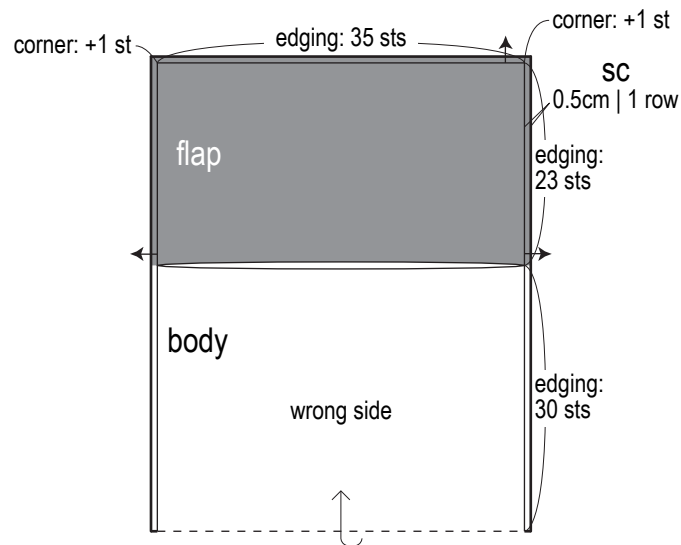

※Work body with 2 strands of yarn held together. Work edging with 1 strand only.