

211F-06 Frilly Tunic



Suggested yarn:

- Pierrot Yarns Cutie Mohair [28% kid mohair, 28% acrylic, 14% superwash wool, 30% nylon; 339 yds/310m per 0.88 oz./25g skein]; color #36 cherry pink, 6 skeins [150g]

Tools/Notions:

- 4.2mm (approx. US 6) knitting needles or size necessary to achieve gauge
- 3.5mm (US E) crochet hook or size necessary to achieve gauge

Finished measurements:

- bust 90cm/35.43"
- cross back width 36.5cm/14.37"
- length 80cm/31.50"

Gauge (10cm/4" square):

- pattern stitch: 19 sts and 30 rows
- grid stitch: 5.5 pattern repeats and 0.7 rows

Gauge may vary according to individual knitting style. Change needle size if necessary to achieve gauge. Alternatively, rework pattern with your own gauge measurements.

Knitting Tips

※Entire garment worked with yarn held doubled.

Back and front bodice: Cast on with long-tail cast-on method and work upper body in pattern stitch A. Seam shoulders with slip stitch. Seam sides with mattress stitch.

Skirt: Working into cast-on edge of upper body, crochet pattern stitch B in the round. Continue in grid stitch (in the round), working evenly spaced increases. After grid stitch section, continue in net stitch C. Work ruffles in net stitch A and net stitch B where indicated (working first round into grid stitch section).

Finishing: Crochet a cord, then thread through eyelets in pattern stitch B. Working edging around armholes and neckline.

Abbreviations:

BO = bind off
ch = chain
CO = cast on
dc = double crochet (US)
inc = increase
RE = row(s) even
rep = repeat(s)
= rows-stitches-times

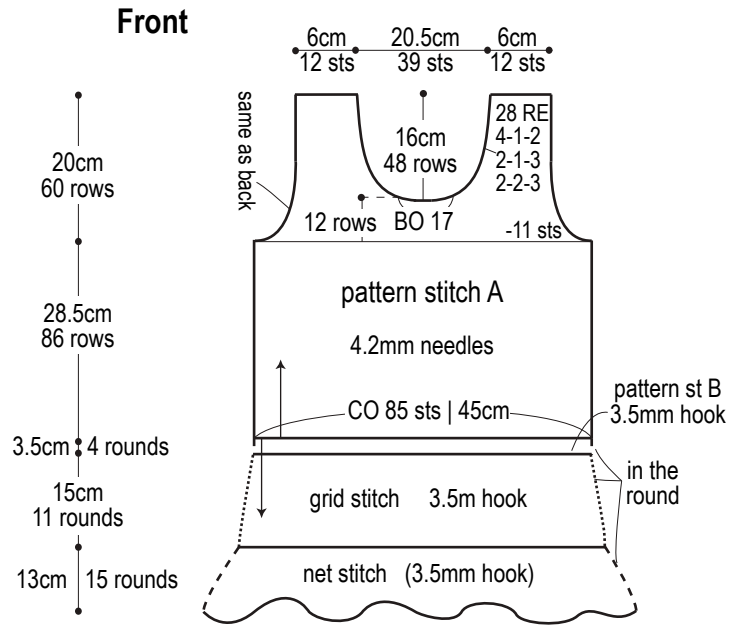
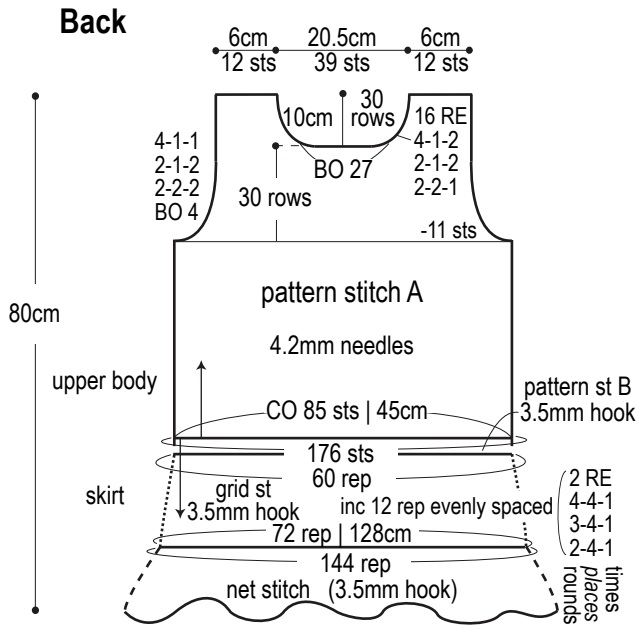

Note: in skirt section, ### indicates rounds-places-times (rather than rows-stitches-times).

Over 11 rounds, you will increase 12 pattern repeats, increasing in 4 evenly spaced places per increase round. Each pattern repeat is 3 sts, so you will increase 3 sts in each of 4 places per increase round (adding a total of 12 stitches per increase round).

Pattern stitch A

4.2mm needles

□ = □ knit

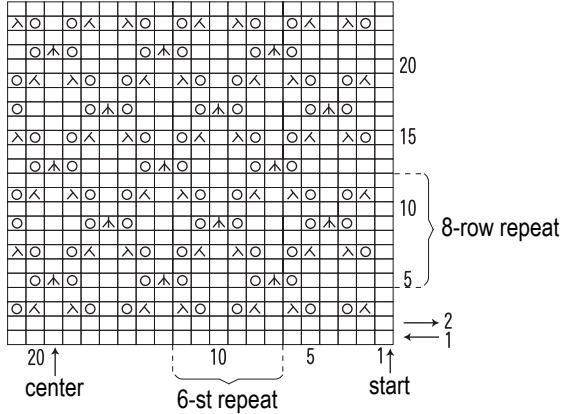

Arm/neckline edging (3.5mm hook)

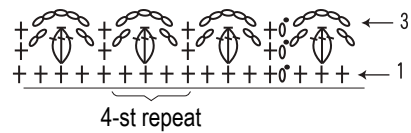

Arm/neckline finishing

edging (3.5mm hook)

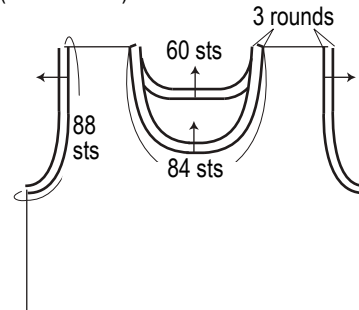

Cord (3.5mm hook)

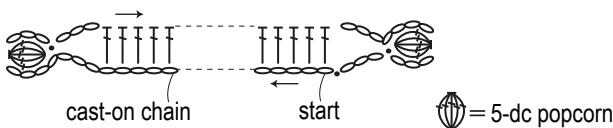

← 2.5cm → 275 sts | 125cm → 2.5cm →

Pattern stitch B (3.5mm hook)

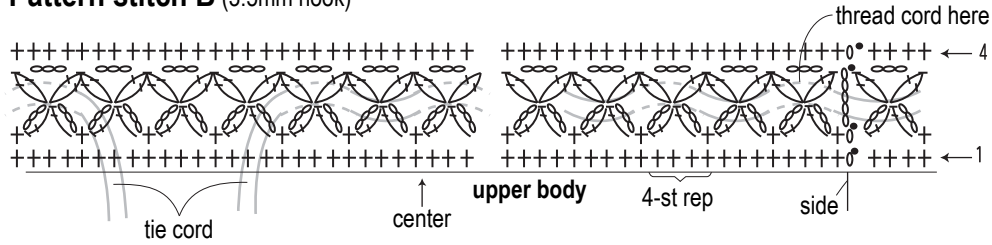

Transition from grid stitch to net stitch

3.5mm hook

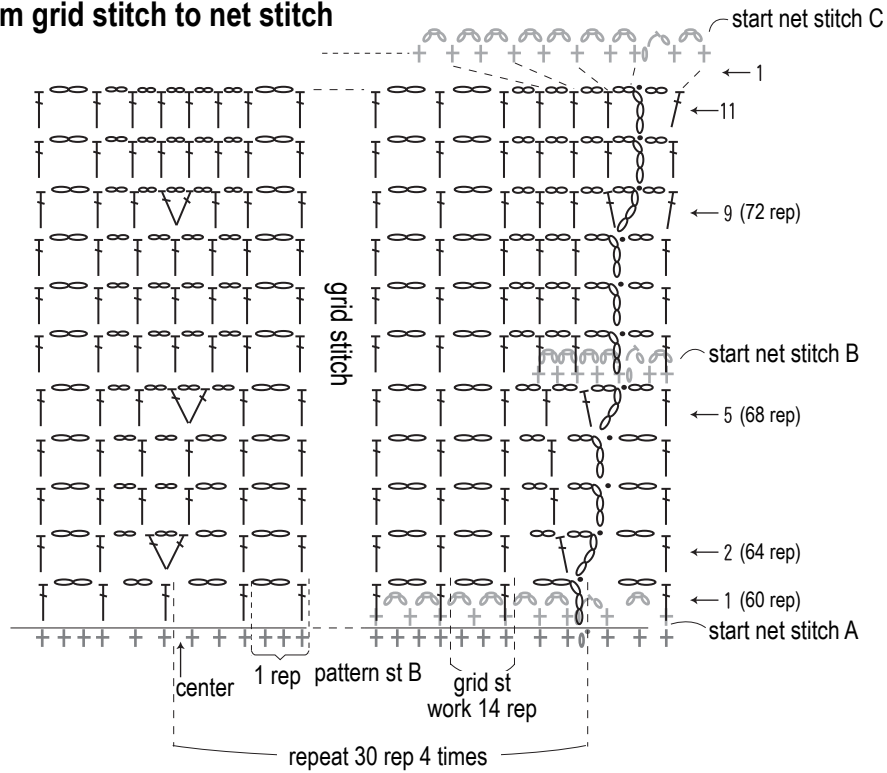

Skirt (3.5mm hook)

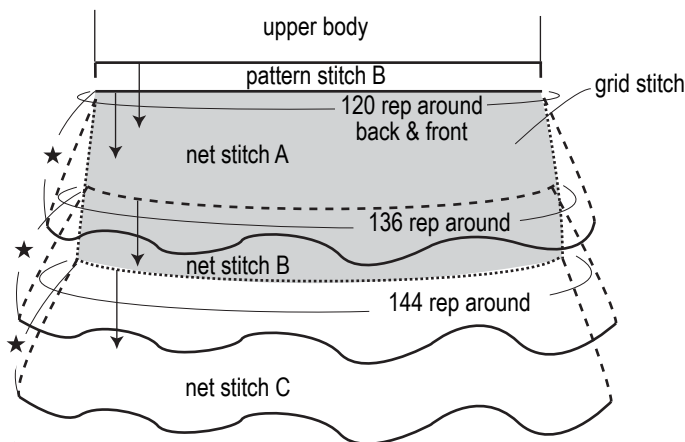

★ = 15 rounds

※ Work net stitch C as a continuation of grid stitch. Work net stitch A and B into grid stitch rounds where indicated.

Net stitch A, B, C (3.5mm hook)

